

VORTEX

OWNER'S MANUAL

VR-3500

Functional Trainer Rack Pack

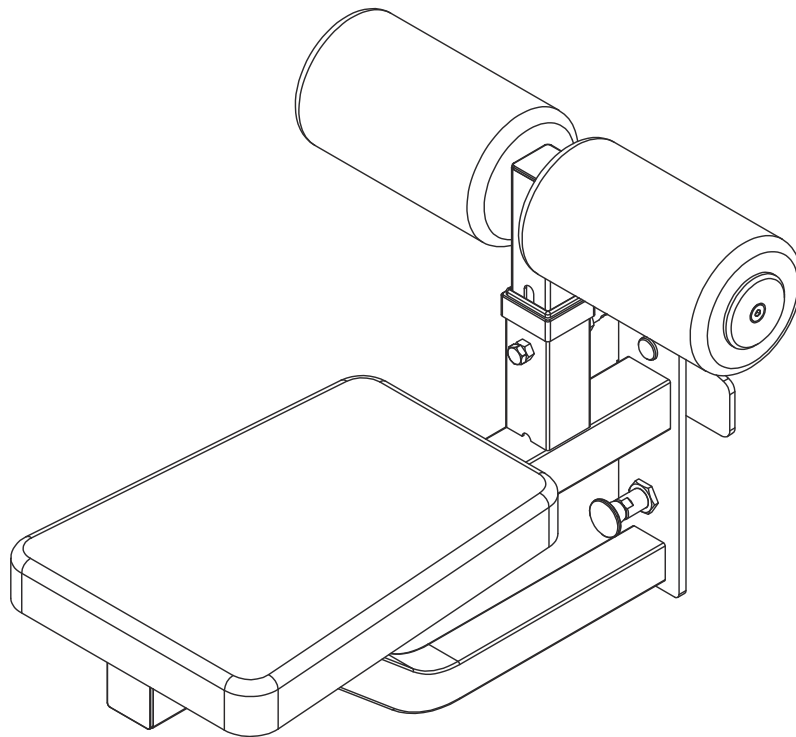

CAUTION!

Read all precautions and instructions in this manual before using this equipment.

20241014V1.0

ASSEMBLY MANUAL

Functional Trainer Rack Pack

BEFORE YOU START

Remove all parts from the packaging and separate and count each various component to ensure everything has been correctly provided.

Follow the instructions and consult both the individual assembly pages and the overall expanded views of the equipment.

Certain parts may arrive pre-assembled from the factory.

It is the owner's responsibility to ensure that all users of this unit have read the owner's manual and are familiar with the safety precautions.

SAFETY PRECAUTIONS

- Highly recommended for two or more people to assemble the equipment to avoid injury.
- Assemble the equipment on a flat level surface.
- Consider placing a mat under the equipment to protect your floor.
- Wear appropriate footwear and clothing during assembly and use.
- Only tighten nuts and bolts by hand until the whole equipment is assembled
- Ensure you correctly orientate each piece before attaching
- Do not allow children and pets to be unsupervised around the assembly or usage of this equipment.
- Ensure all parts are in full working order before use.
- Only one person should use the machine at any one time.
- Do not use the equipment outdoors or around water.
- Keep hair, fingers or clothing away from moving parts.
- Only use attachments recommended by the manufacturer.
- Never operate if any parts are not functioning correctly.
- Always correctly stretch and warm up before using the equipment.
- **Stop immediately** if you experience any pain, dizziness or nausea. See a doctor at once.

PLEASE NOTE: Descriptions of pieces as LEFT and RIGHT are from the point of view of standing behind the equipment facing towards the front.

BEFORE STARTING ANY EXERCISE PROGRAM, CONSULT YOUR DOCTOR. ESPECIALLY IF YOU ARE OVER THE AGE OF 35 OR HAVE PRE-EXISTING HEALTH PROBLEMS.

READ ALL INSTRUCTIONS BEFORE ASSEMBLING OR USING ANY FITNESS EQUIPMENT.

WE ASSUME NO RESPONSIBILITY FOR PERSONAL INJURY OR PROPERTY DAMAGE SUSTAINED BY OR THROUGH THE USE OF THIS PRODUCT.

SAVE THESE INSTRUCTIONS.

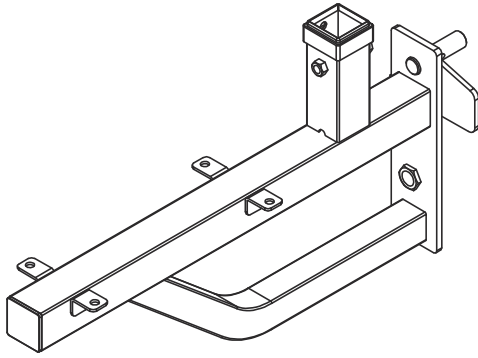

① ×1

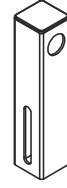

② ×1

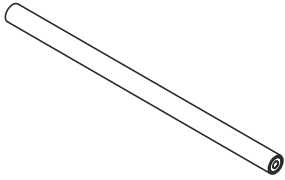

③ ×1



④ ×2

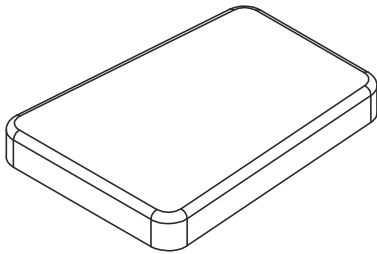

⑤ ×1

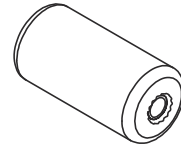

⑨ ×2



⑩ ×2

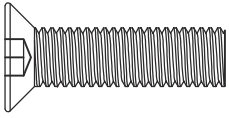

⑪ ×2

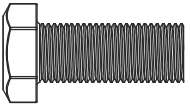

⑫ ×4

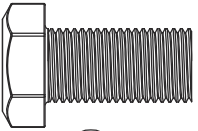

⑬ ×1

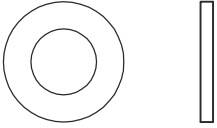

⑭ ×4

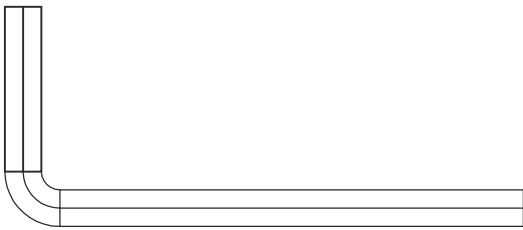

5#×1

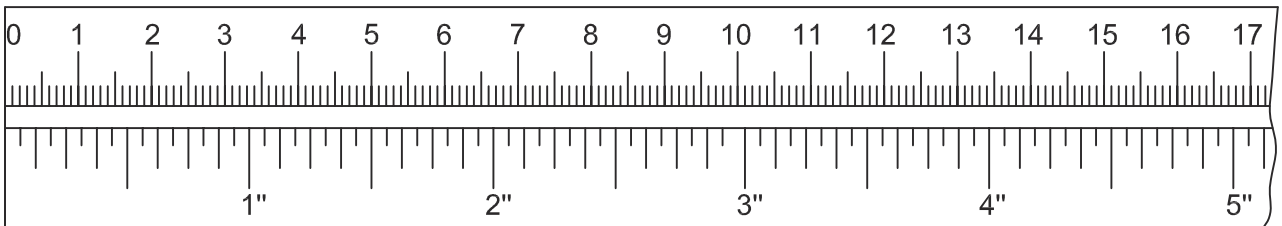

12

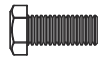

× 4

M8×20mm

14



× 4

Φ8

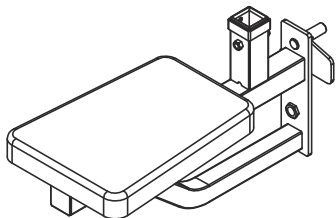
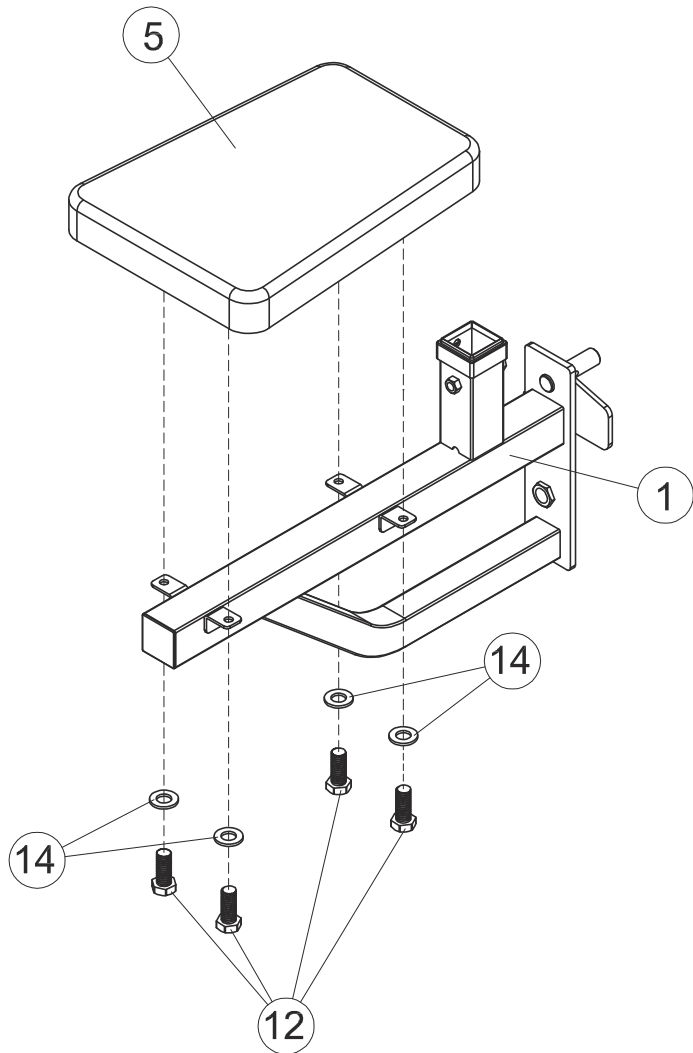
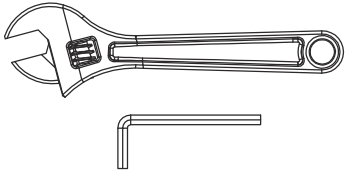

1

13



× 1

M10×20mm

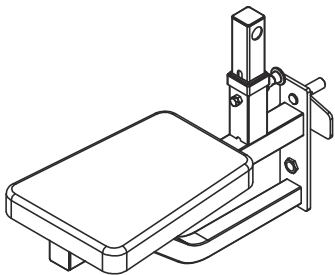
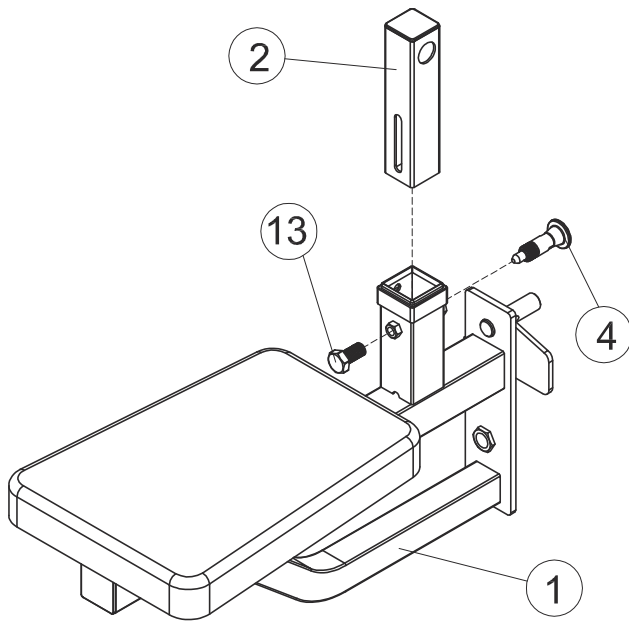
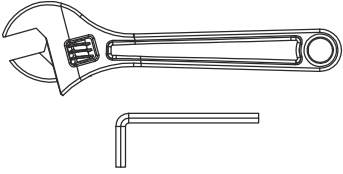

2

11



× 2

M8×30mm

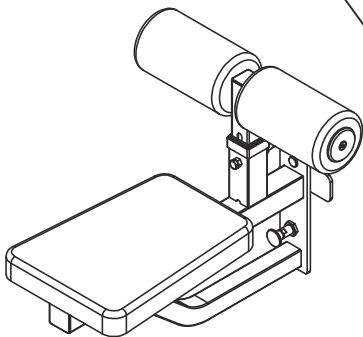
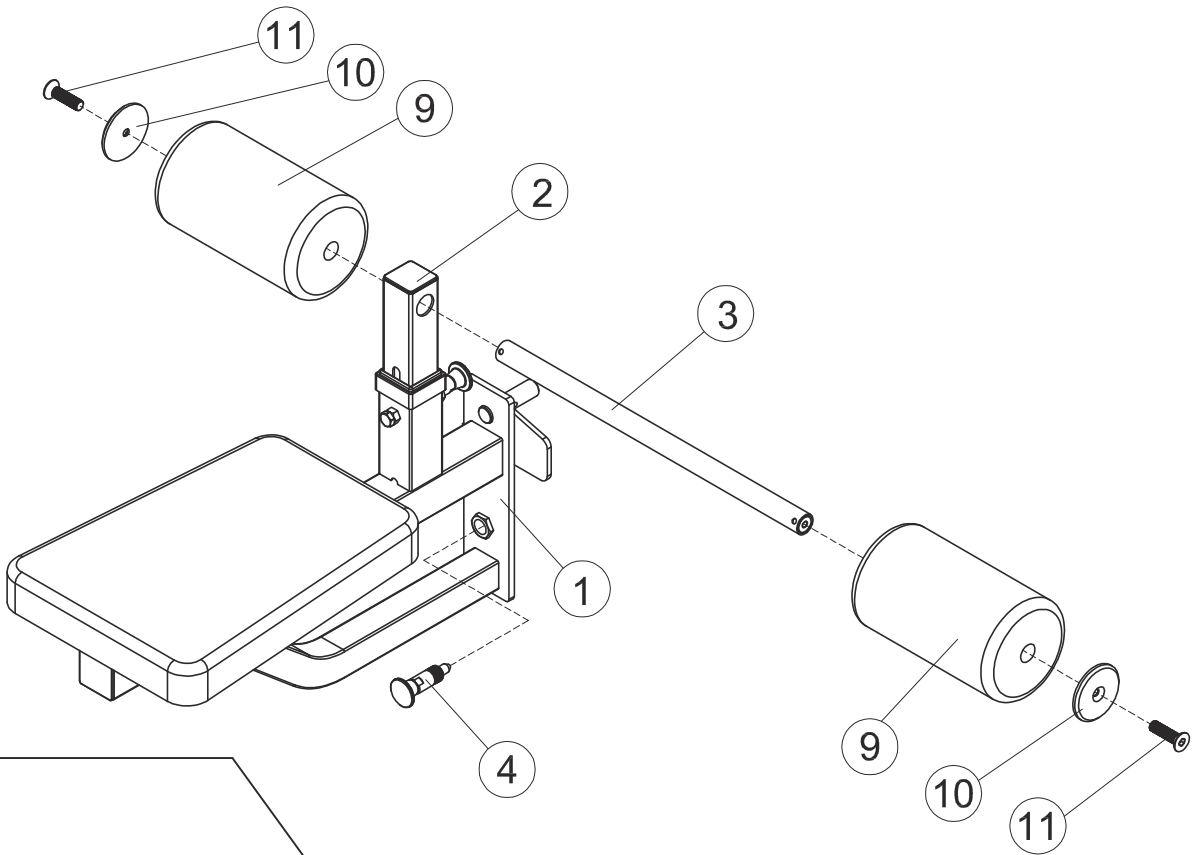
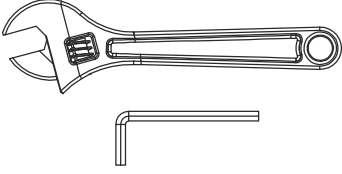

3

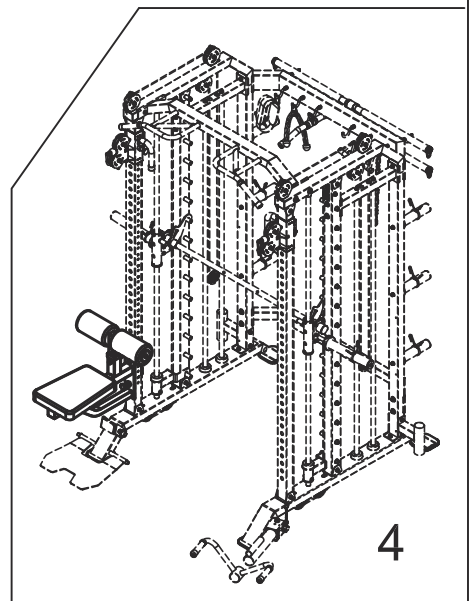
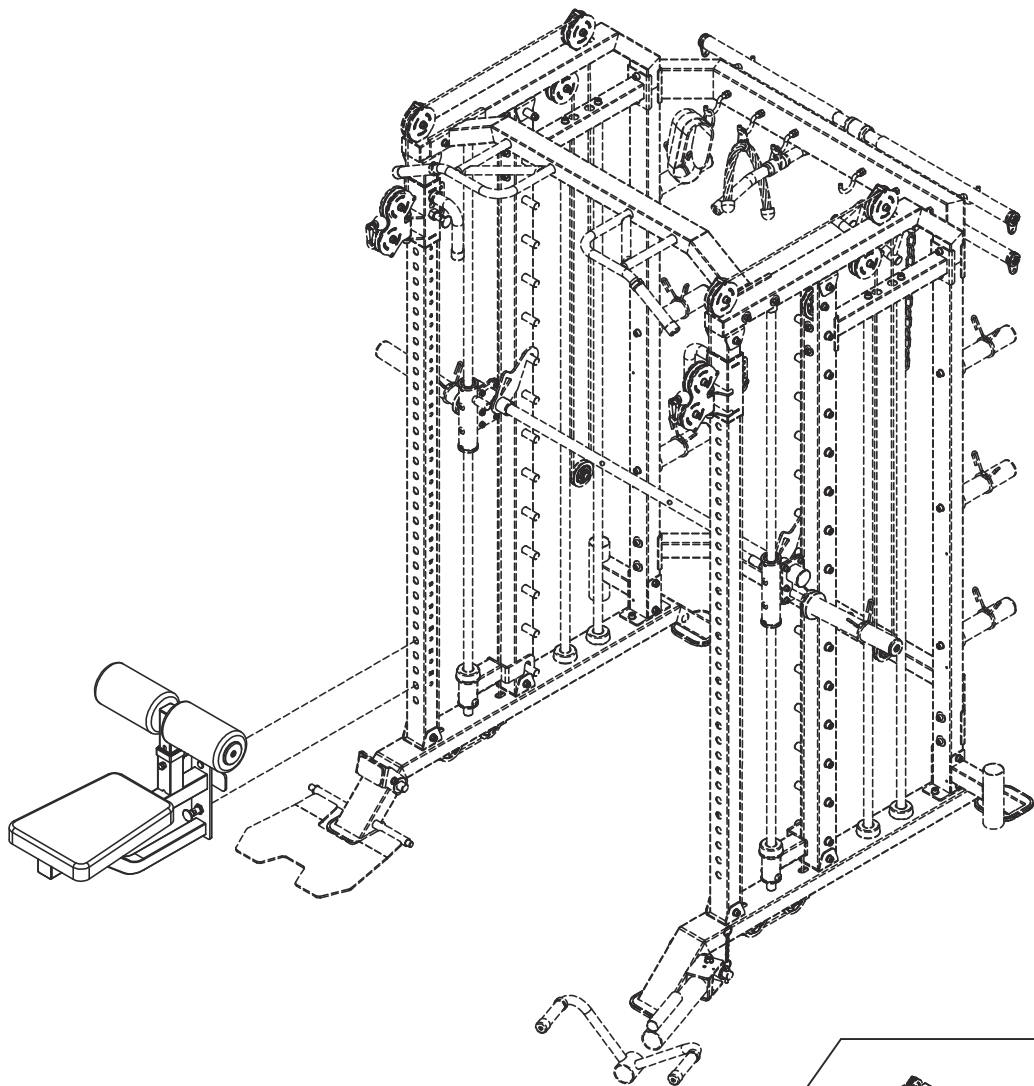

EXPLODED DIAGRAM

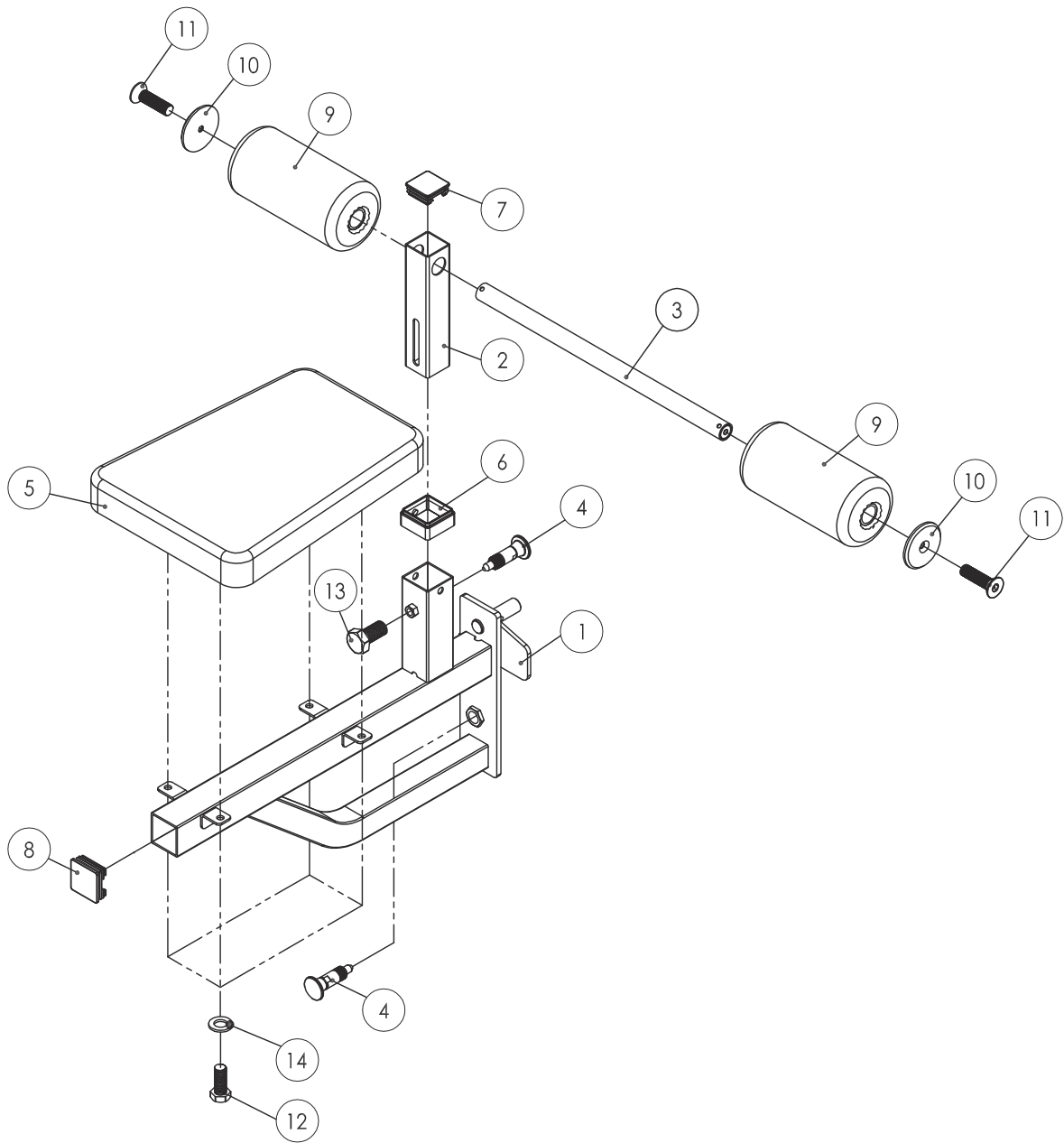

PARTS LIST

KEY NO.	PART DESCRIPTION	SPEC	QTY
1	Seat Support		1
2	Adjust To Pipe		1
3	Foam Roll Frame		1
4	Lock Knob		2
5	Seat Pad		1
6	Sleeve	□50×□45	1
7	End Cap	□44	1
8	End Cap	□50	1
9	Foam Roll	φ125×φ22×215	2
10	Foam Baffle	φ68×5.7	2
11	Sunk Screw	8×30	2
12	Hex Bolts	8×20	4
13	Hex Bolts	10×20	1
14	Washer	8	4
	Allen Wrench	5#	1