

Installation and Operation Manual

Deluxe Dumbbell Stool

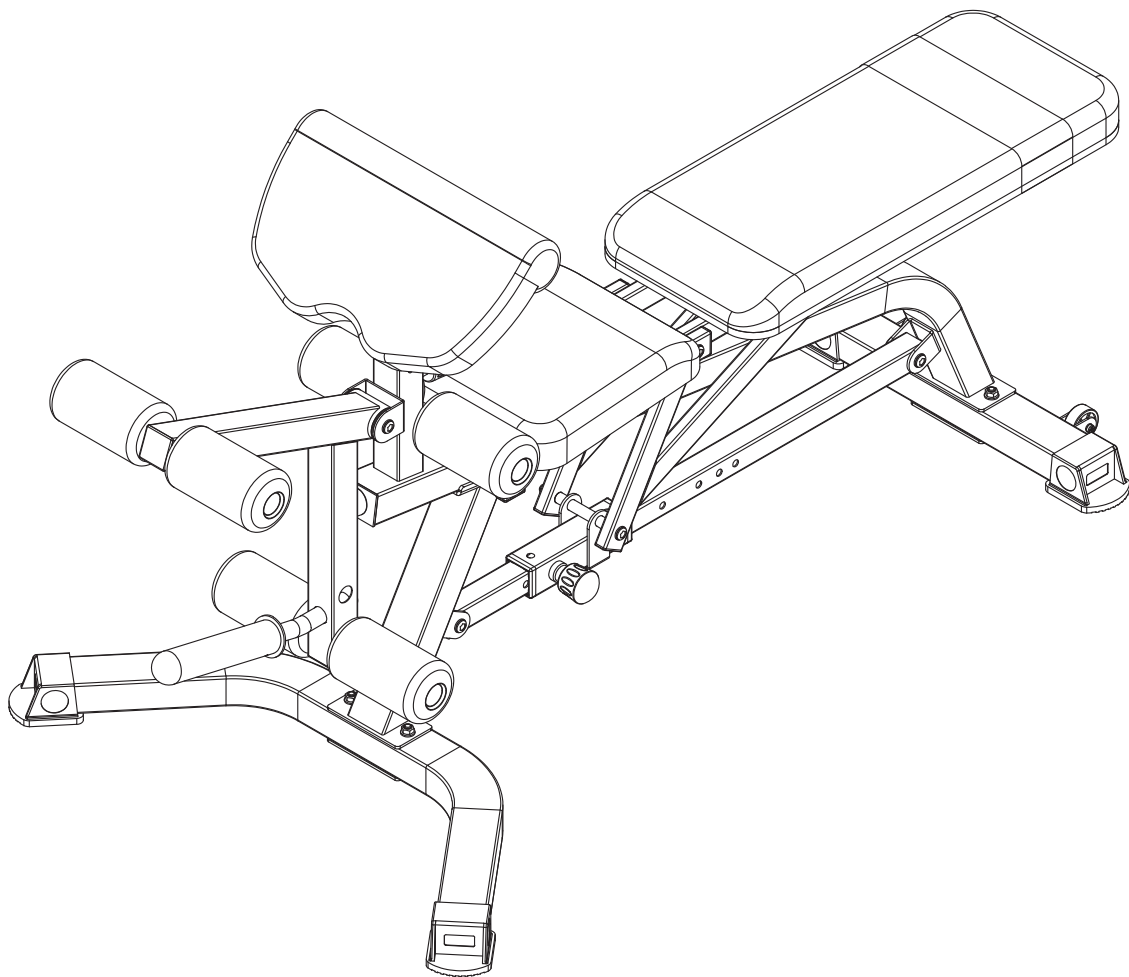

Important safety knowledge.....1
Exploded view.....2
Parts list.....3-4
Instruction for assembly.....5-10
Training instruction.....11
Training record.....12

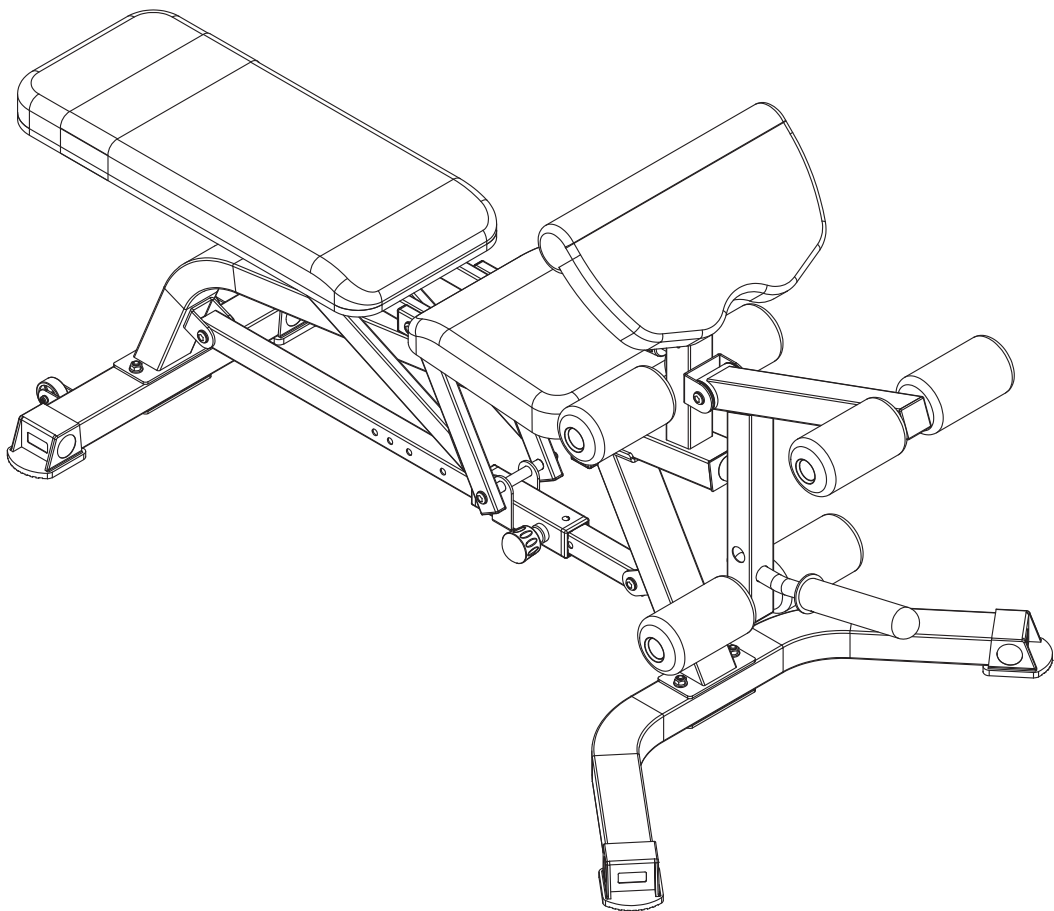

Please keep this instruction manual properly for reference in the future.

Precautions

Although the training equipment has taken the safety precautions into consideration as much as possible during the design and manufacturing process, there are still some safety precautions which needs to be observed during the operation. Please read the instruction manual carefully before assembling and using the training equipment, especially the following safety precautions:

1. Keep children, pets, etc. away from the training equipment, and don't allow unattended children to stay alone in the room where the training equipment is placed.
2. The training equipment can only be used by one person at a time.
3. If the user feels dizziness, nausea, chest tightness or have other uncomfortable symptoms, stop using the training equipment immediately and see a doctor immediately.
4. The training equipment shall be placed on a clean and flat surface. The training equipment shall not be used near the water or outdoors.
5. When using the training equipment, keep hands away from any transmission parts.
6. When using the training equipment for training, the dress shall be suitable for training. Don't wear loose or other types of clothes that may be stuck during the training process. It is also recommended to wear sports shoes or healthcare shoes as much as possible during the training process.
7. In the process of using the training equipment, users can only do in the manner described in the operating instructions, and it is forbidden to use the training methods which are not mentioned in the operating instructions for training.
8. Avoid placing any objects with sharp parts around the training equipment.
9. Any disabled person is not allowed to use the training equipment without the supervision of the training partners or nursing staff.
10. Before training, it usually required to warm up by doing various stretching exercises.
11. If the training equipment has abnormal functions, it is forbidden to use it.
12. In the process of training, the training records require to be made at any time.
13. The training equipment is not suitable for use as medical equipment.
14. The maximum user weight of this product is 120kg.

Exploded view

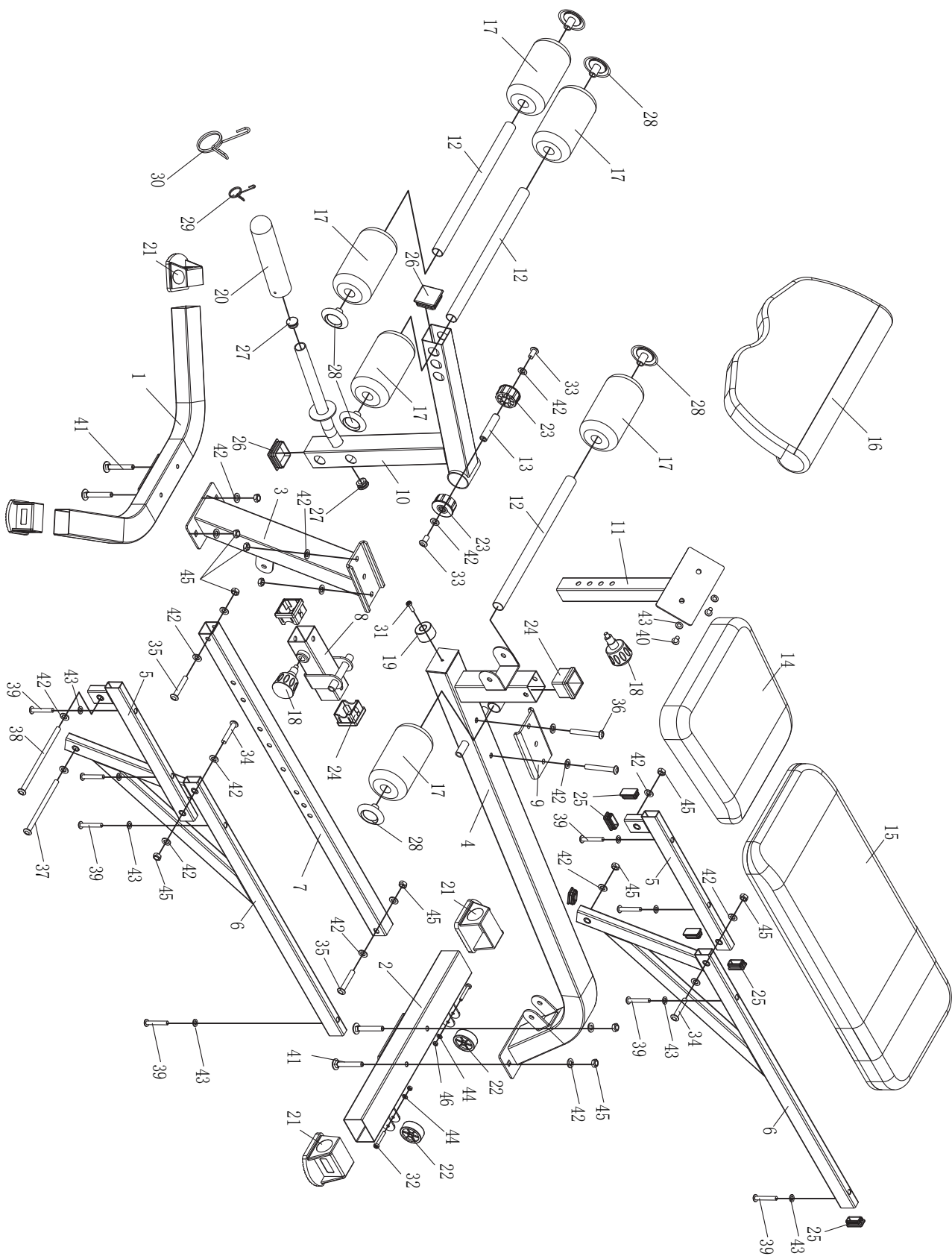

Parts list

Parts list					
Serial number	Name and specification	Quantity	Serial number	Name and specification	Quantity
1	Forefoot tube weldment	1	26	50 square tube plug	2
2	rear leg pipe weldment	1	27	25 internal plug of the round tube	2
3	Front support weldment	1	28	25 Round tube end cover plug	6
4	Seat / Backrest cushion main frame	1	29	Small clip clutch	1
5	Seat cushion frame	2	30	Big clip clutch	1
6	Backrest cushion frame	2	31	Cross recessed pan head screwsM6*20	1
7	Slip pipe	1	32	Cross recessed pan head screwsM6*40	2
8	Adjustable bracket	1	33	Hexagon socket pan-headed boltM10*20	2
9	Stiffening plate	1	34	Hexagon socket pan-headed boltM10*55	6
10	Leg curling supporting frame	1	35	Hexagon socket pan-headed boltM10*60	2
11	Hand pad adjusting pipe	1	36	Hexagon socket pan-headed boltM10*75	2
12	sponge holder tube	3	37	Hexagon socket pan-headed boltM10*155	1
13	Rotation shaft	1	38	Hexagon socket pan-headed	1

				boltM10*195	
14	Seat cushion	1	39	Hexagon socket pan-headed boltM8*55	8
15	Backrest cushion	1	40	Hexagon socket pan-headed boltM8*15	2
16	Hand pad	1	41	Pan head square neck boltM10*70	4
17	sponge holder	6	42	Flat padΦ10	22
18	Spring pin	2	43	Flat padΦ8	10
19	Shock pad	1	44	Flat padΦ6	2
20	Barbell cover	1	45	Jam nutM10	12
21	Foot cover	4	46	Jam nutM6	2
22	Roller	2	47		
23	Plastic shaft sleeve	2	48		
24	Bushing between pipes	3	49		
25	Rectangular tube plug	12	50		
TOOL					
	Spanner 13# and 17#	1		Hex wrenches5#	1
	Hex wrenches6#	2		Hex wrenches4#	1

Instruction for assembly

Step 1

1. Place the front support weldment (3) and the forefoot tube weldment (1) in accordance with the picture, and use the pan-head square neck bolts M10*70 (41), Φ 10 flat pad (42) and M10 jam nut (45) to fix and fasten tightly.
2. Put the seat cushion main frame (4) and rear leg pipe weldment (2) in accordance with the picture, and use pan-head square neck bolts M10*70 (41), Φ 10 flat pad (42) and M10 jam nut(45) to fix and fasten tightly.
3. Align the front support weldment (3), seat/cushion main frame (4) and stiffening plate (9) with the holes in accordance with the picture, and use M10*75 hexagon socket pan-headed bolts (36), Φ 10 flat pads (42), and elastic pad M10 (41) and M10 jam nut (45) to fix and fasten tightly.

Note: After adjusting the main part to a balanced state, tighten the corresponding bolts and nuts.

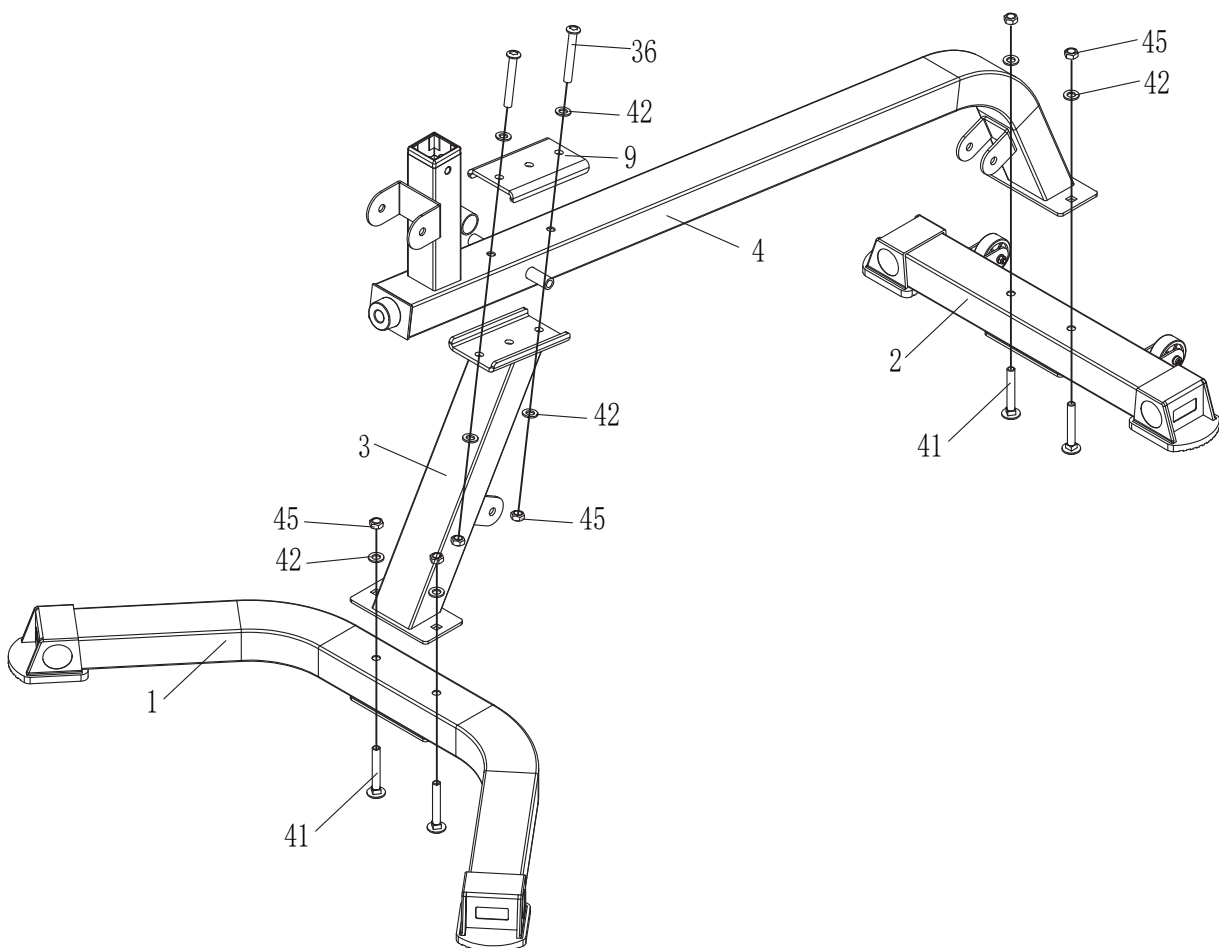

Step 2

1. Insert the adjustable frame (8) into the slip pipe (7) in accordance with the picture, and screw the spring pin (18) into the adjustable frame (8). Then, place the two ends of the assembled slip pipe (7) and the front support weldment (3) and the seat cushion main frame (4). Align the holes. Use the M10*60 hexagon socket pan-headed bolts (35), Φ 10 flat pads (42) and M10 jam nut (45) to fasten and fix tightly.

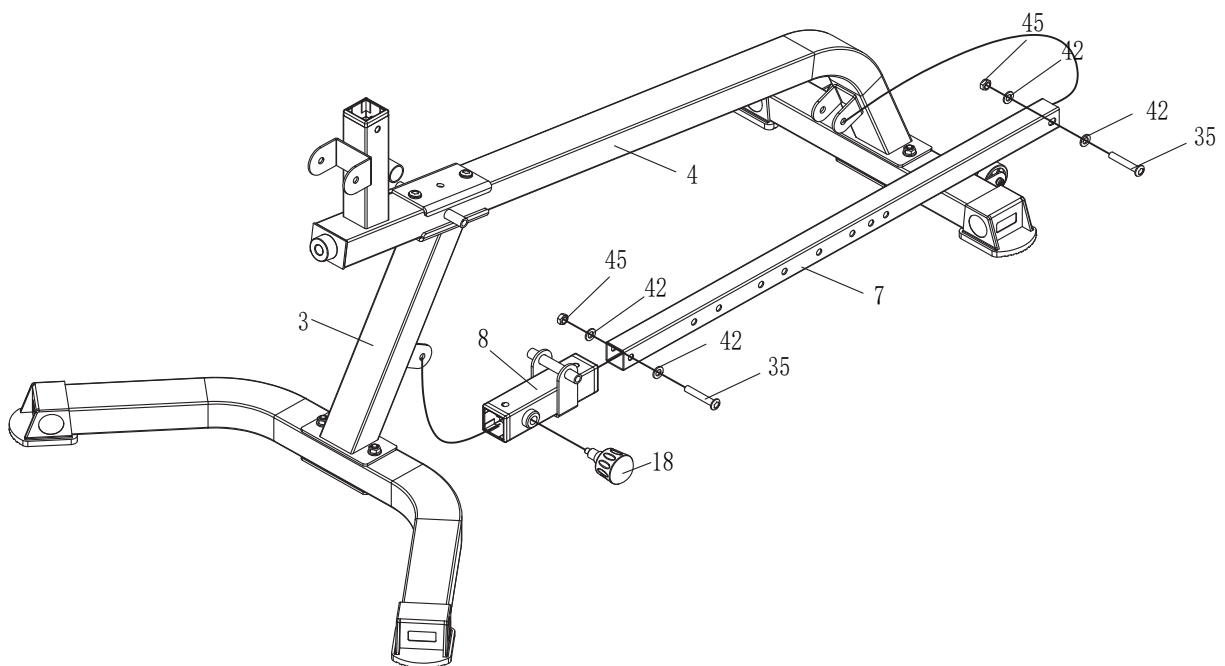

Step 3

1. Align the seat/cushion main frame (4) and the seat cushion frame (5) with the holes in accordance with the picture, and use M10*195 hexagon socket pan-headed bolts (38), Φ 10 flat pads (42) and M10 jam nut (45) to fix and fasten.
2. Align the backrest cushion frame (6) and the adjustable frame (8) with the holes in accordance with the picture, and fix them with M10*155 hexagon socket pan-headed bolts (37), Φ 10 flat pads (42) and M10 jam nut (45) to fasten and fix tightly.
3. Align the backrest cushion frame (6) and the seat cushion frame (5) with the holes in accordance with the picture, and use M10*55 hexagon socket pan-headed bolts (34), Φ 10 flat pads (42) and M10 jam nut (45) to fasten and fix tightly.
4. Insert the hand pad adjusting pipe (11) into the seat / backrest cushion main frame (4) in accordance with the picture, and fix and tighten with the spring pin (18).

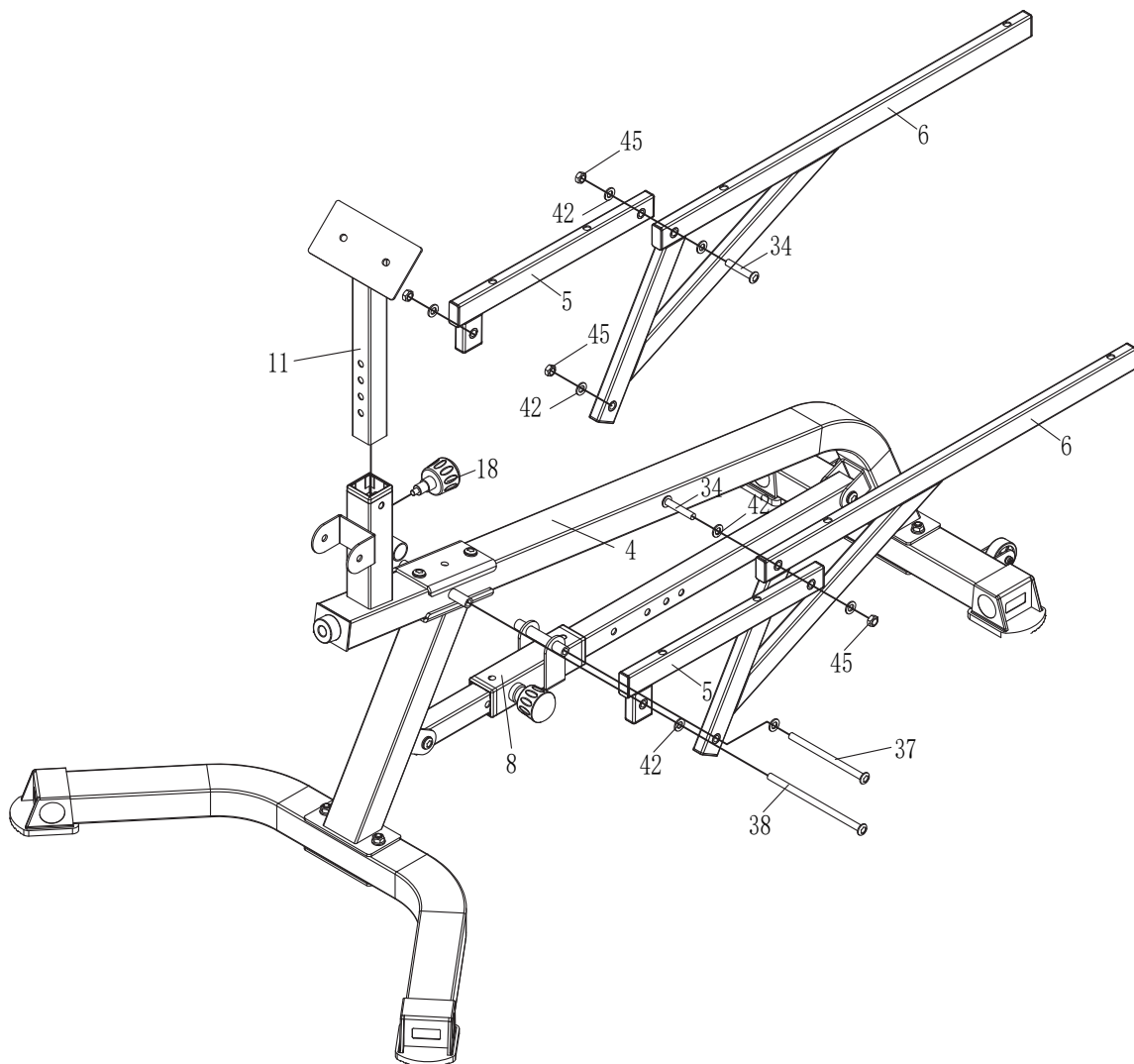

Step 4

1. Take the seat cushion (14) in accordance with the picture, and fix it on the seat cushion frame (5) with M8*55 hexagon socket pan-headed bolts (39) and $\Phi 8$ flat pad (43); 2. Take the backrest cushion (15) in accordance with the picture and fix it on the backrest cushion frame (6) with M8*55 hexagon socket pan-headed bolts (39) and $\Phi 8$ flat pad (43); 3. Take the hand pad (16) in accordance with the picture and use M8*15 hexagon socket pan-headed bolts (40) and $\Phi 8$ flat pad (43) to fix it on the hand pad adjusting tube (11).

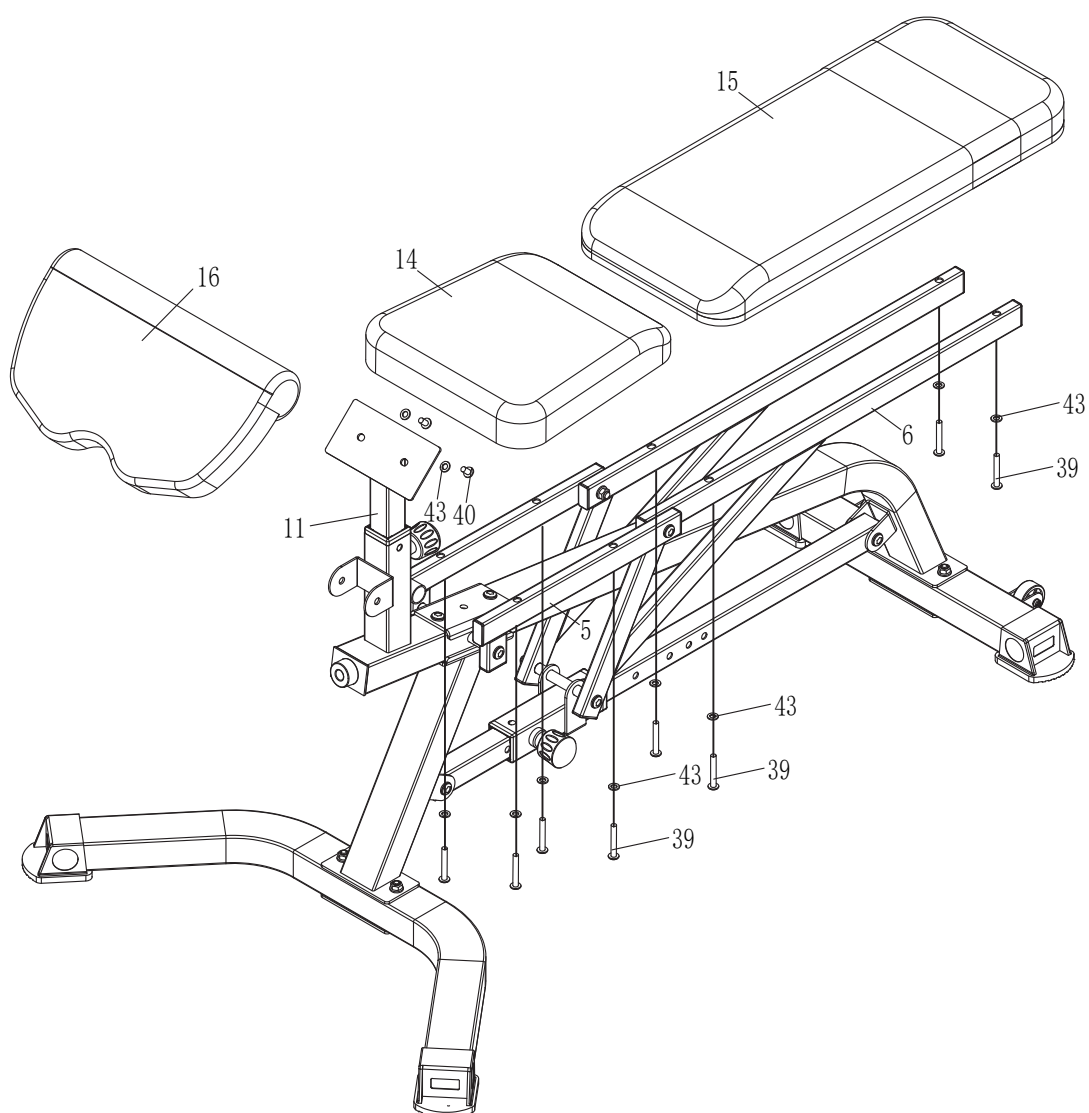

Step 5

1. Assemble the rotating shaft (13) on the leg curling supporting frame (10) in accordance with the picture, and then place it in the assembled seat/cushion main frame (4). Use M10*20 hexagon socket pan-headed bolts (33) and $\Phi 10$ flat pad (42) to fix and fasten the two tightly;

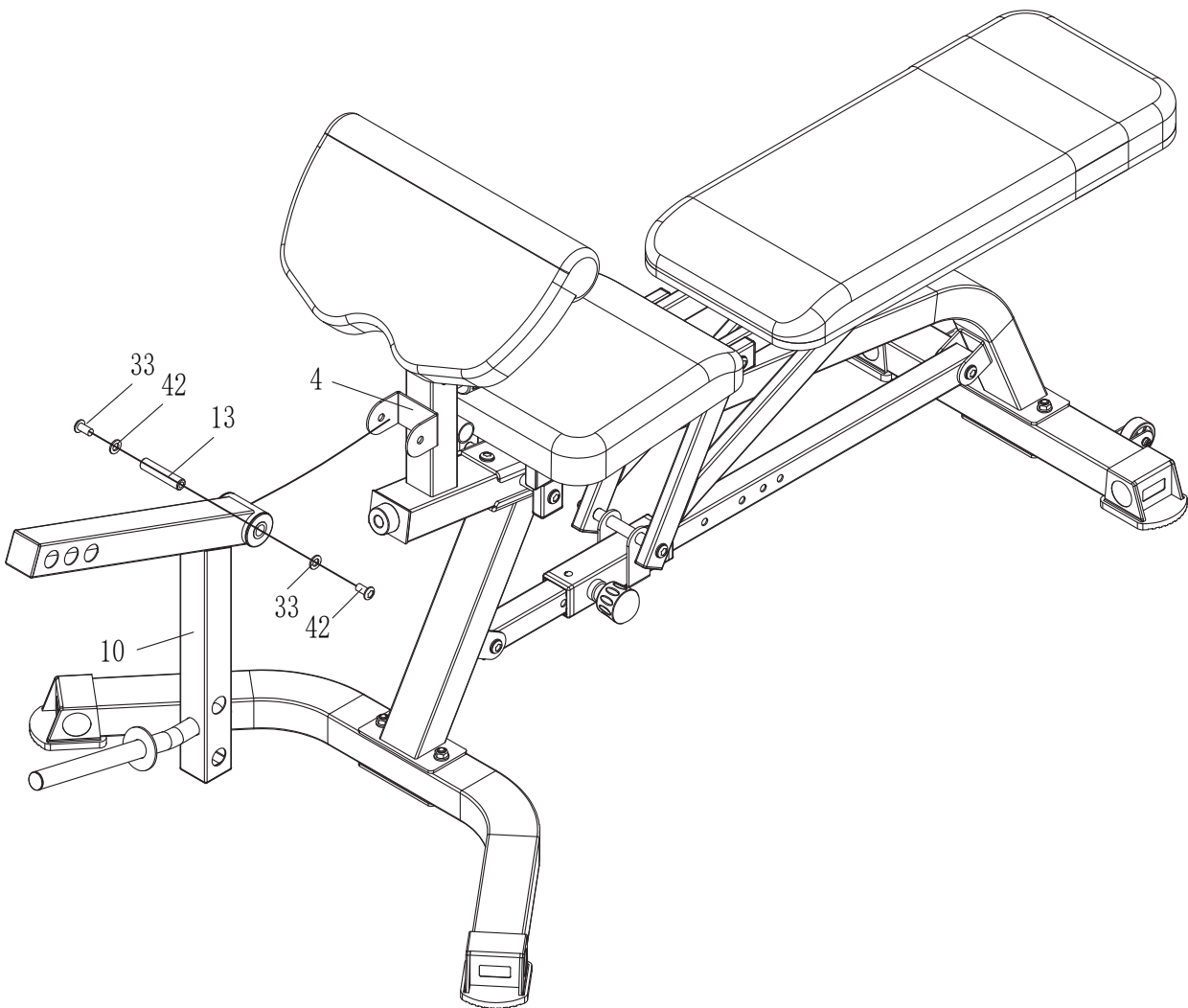

Step 6

1. Assemble the sponge holder tube (12) in the assembled seat/cushion main frame (4) and the the leg curling supporting frame (10) in accordance with the picture, then install the 6PCS sponge holder (17) in accordance with the position shown in the picture, and finally let the 25 Round tube end cover plug (28) installed in the sponge holder tube (12).
2. Assemble the barbell cover (20) on the leg curling supporting frame (10) in accordance with the picture, and fix the barbell cover (20) with a 4# hexagon wrench, and finally install the small clip clutch (29) and the large clip clutch (30).
3. After completing the assembling, check whether the screws are fastened and fixed.

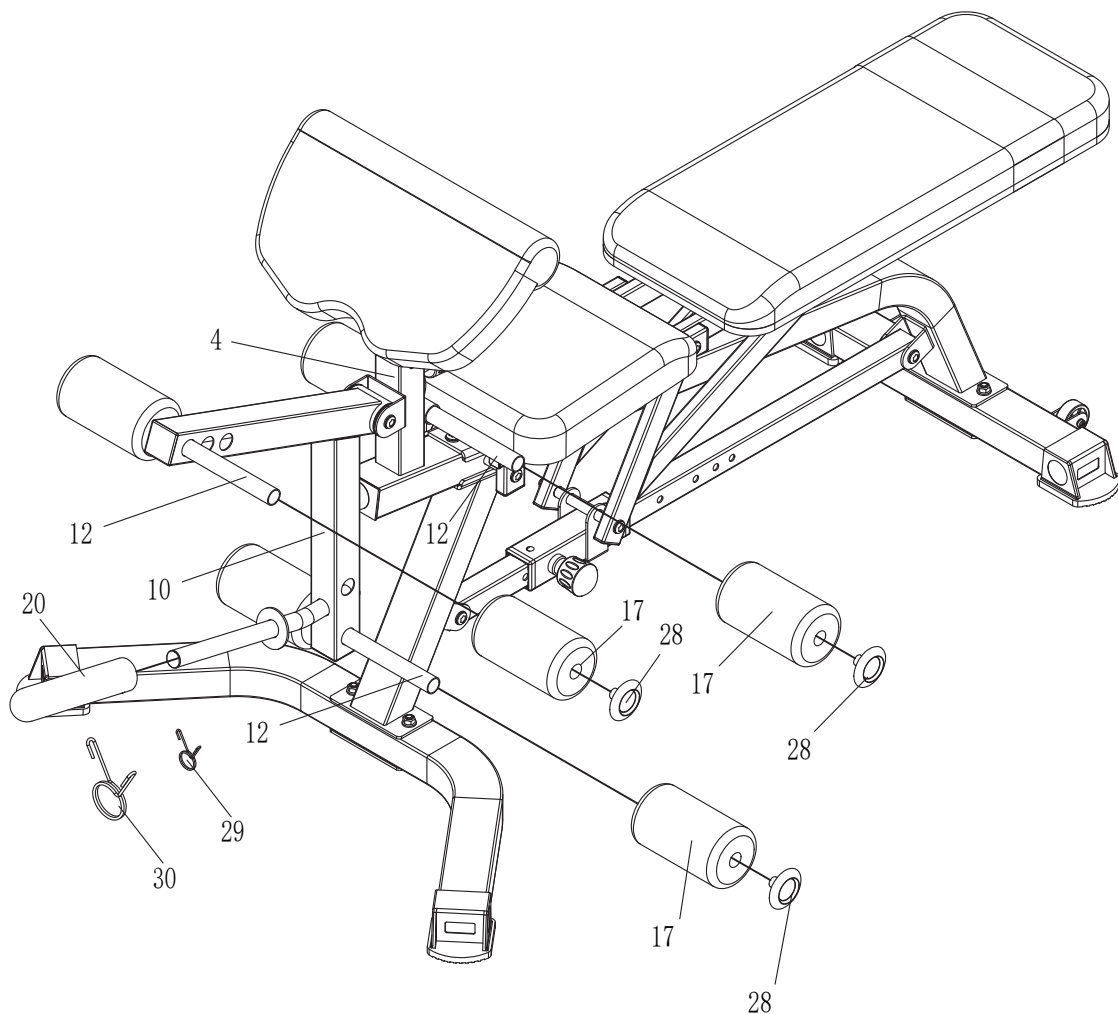

Training instruction

In addition to the functions of enhancing physical fitness and building muscle, this product also plays a role in weight loss through a reasonable diet.

Warm up before training

The warm-up exercise at this stage can enhance the blood circulation of the trainers' bodies and make the muscles reach a good training state, while reducing the risk of cramps or muscle damage during the process of training. Each time before training, please do the warm-up exercises in accordance with the following recommended training methods. Each kind of stretching exercise must be maintained for about 30 seconds. When doing exercises, you must be careful not to do intense stretching exercises to prevent muscle damage. Once the muscle is damaged, please stop exercising.

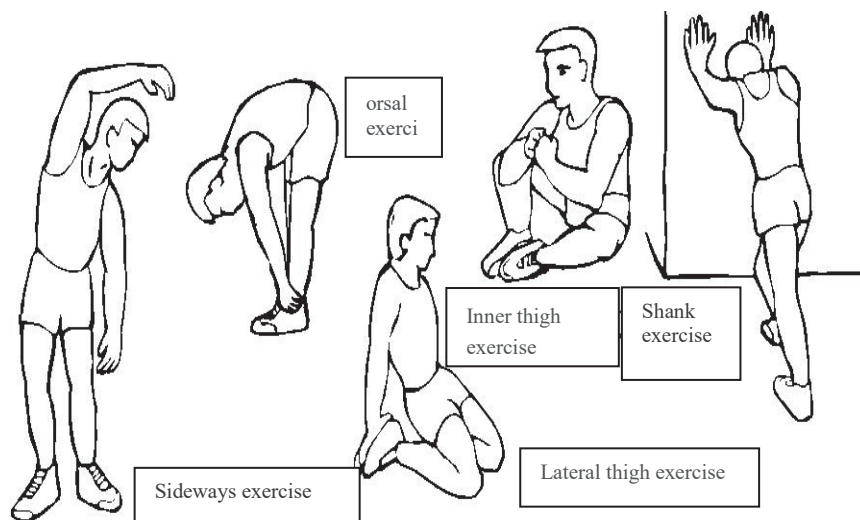

Stage of training

This stage is a formal training stage, and after a long period of regular exercise you can improve the flexibility of the leg muscles. The key to the training process is to exercise with a stable training intensity in accordance with your own training situation. Choose a reasonable training intensity during the exercise and keep your heart rate within the target value range listed in the following table.

Keep the heart rate within the corresponding target range for at least 12 minutes of training. Most people continue training for 15-20 minutes at the beginning of training.

Recovery phase after training

During the recovery phase, repeat the activities in the preparation phase. During the process, you can appropriately reduce the amplitude and speed of the exercise. The time can last for about 5 minutes. You can adjust the body heat through exercise so as to relax the muscles. What should be noted is that vigorous stretching activities can't be done during exercise so as to avoid muscle damage.

In the case when you adapt yourself to training, you can gradually extend the training time and increase the training intensity. It is recommended to train at least 3 times a week, and record the average level of weekly exercise if possible.

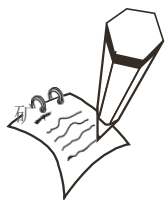

Training record

Use this piece of blank paper to record the results of your training.

